



STRUTTURA E NOMENCLATURA DELLO SCAFO

Raniero Bravetti
Scuola Nautica Teseo Cesena

Principali elementi dello scafo

falchetta

orlo

ombrinale

coperta

- Scafo dislocante o a carena tonda

trincarino

- Scafo planante

- Carena piatta

fasciame

- Carena a V

costola

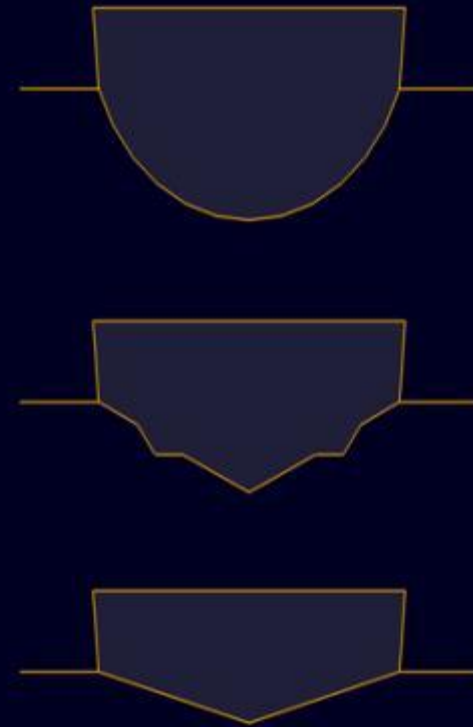

Principali elementi dello scafo



Principali elementi dello scafo

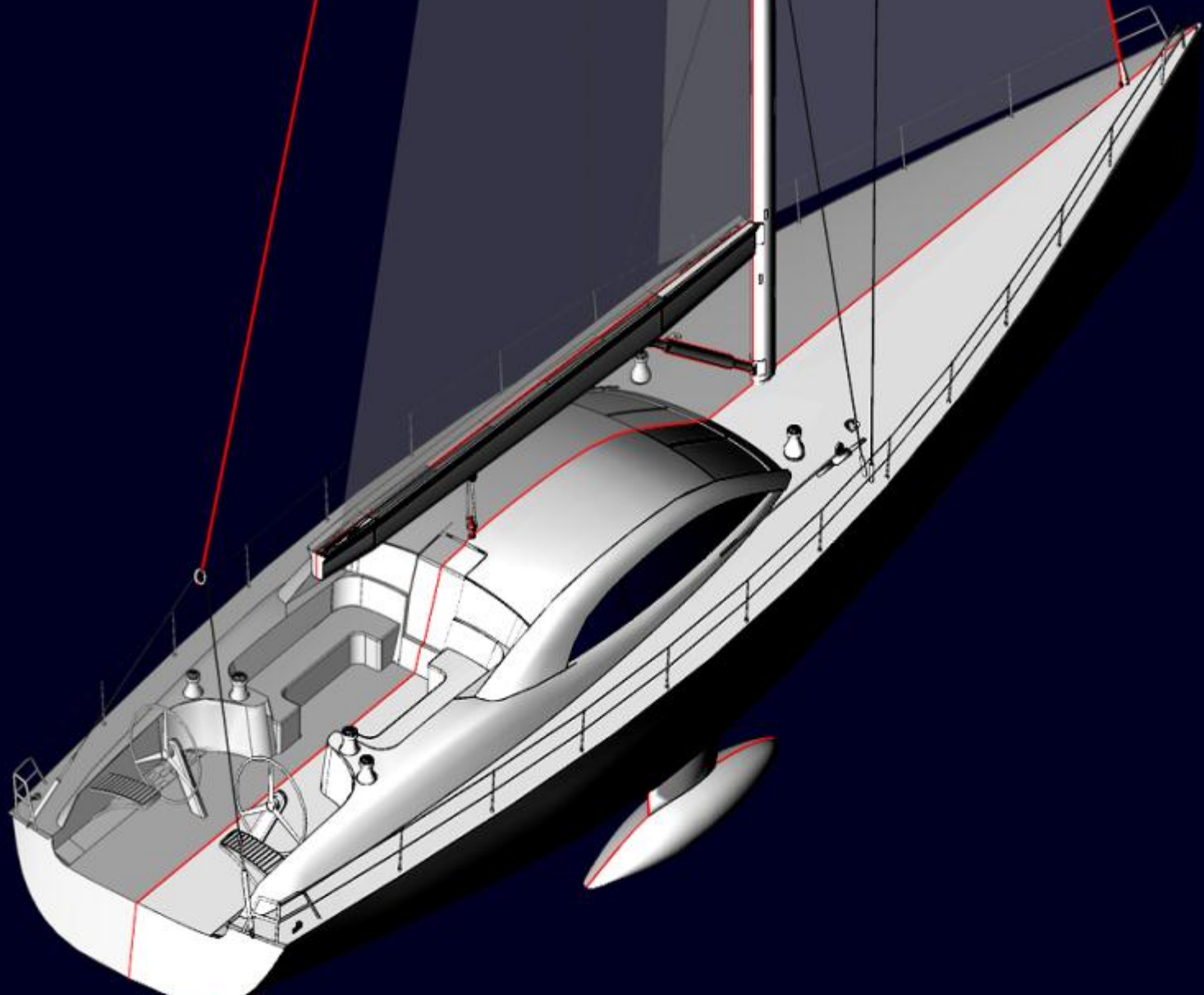

Principali elementi dello scafo



Parte di sinistra

Parte di dritta

Principali elementi dello scafo

Sezione maestra



Principali elementi dello scafo



Zona prodiera

Zona poppiera

Principali elementi dello scafo



Dati tecnici

Sezione maestra



Dati tecnici

Sezione maestra

linea di galleggiamento

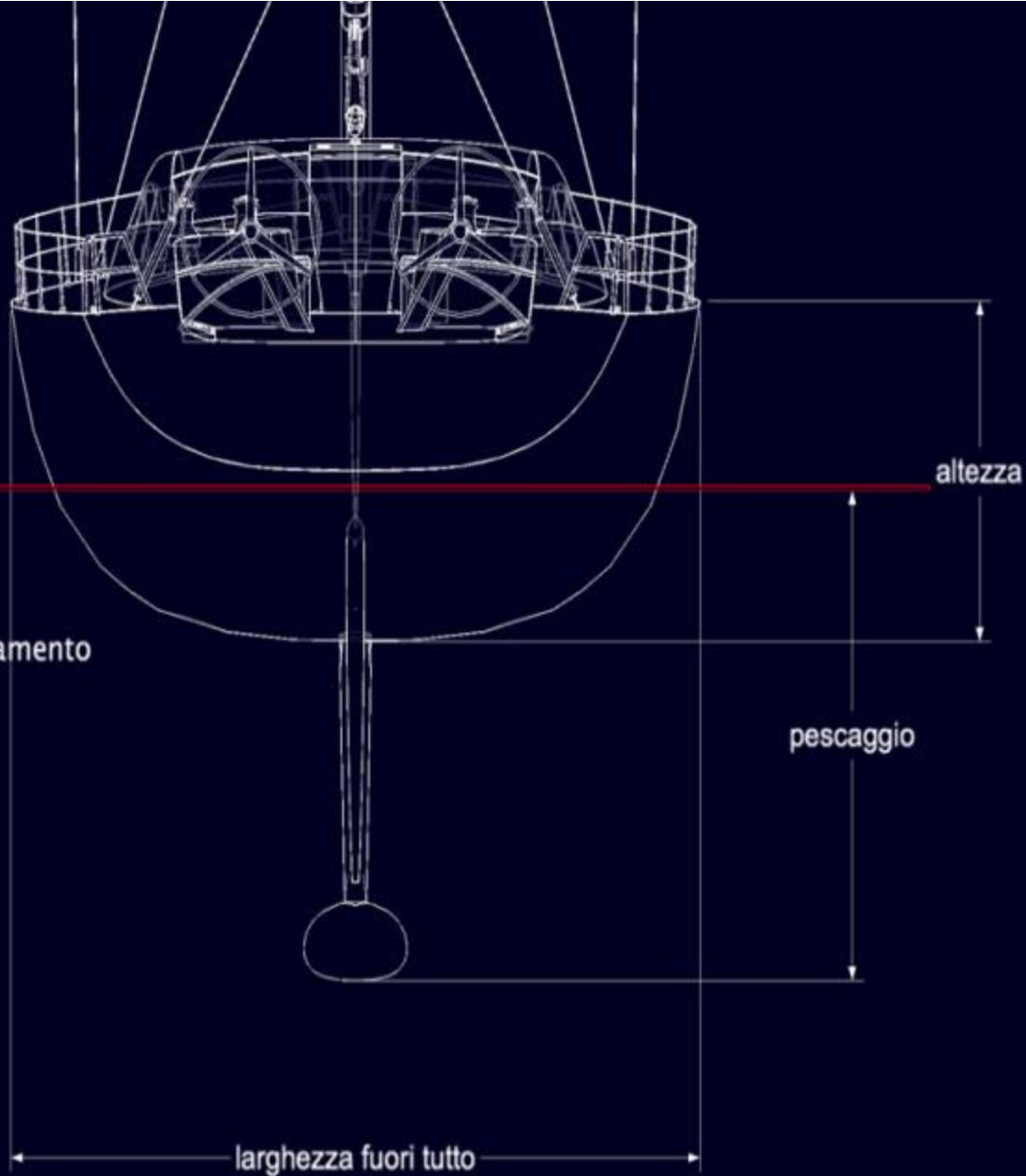

Dati tecnici

- Stazza lorda
- Stazza netta
- Dislocamento
- Portata



Struttura dello scafo

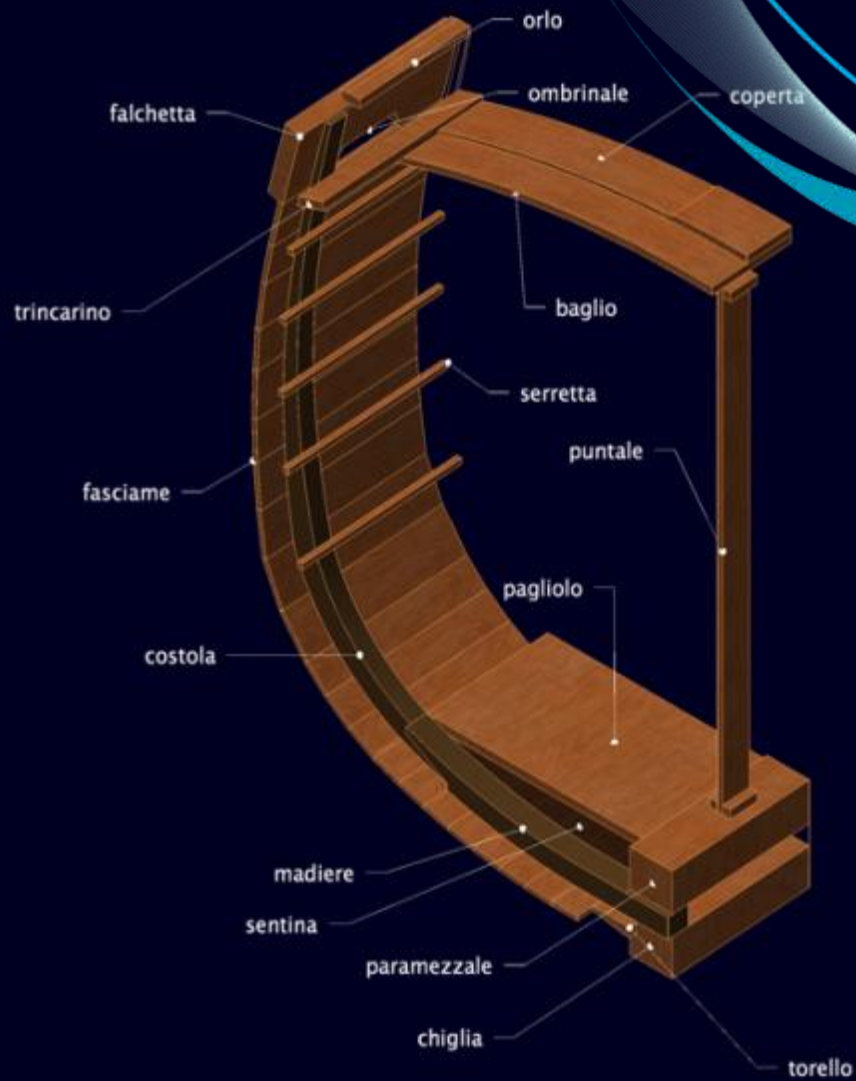

Struttura dello scafo

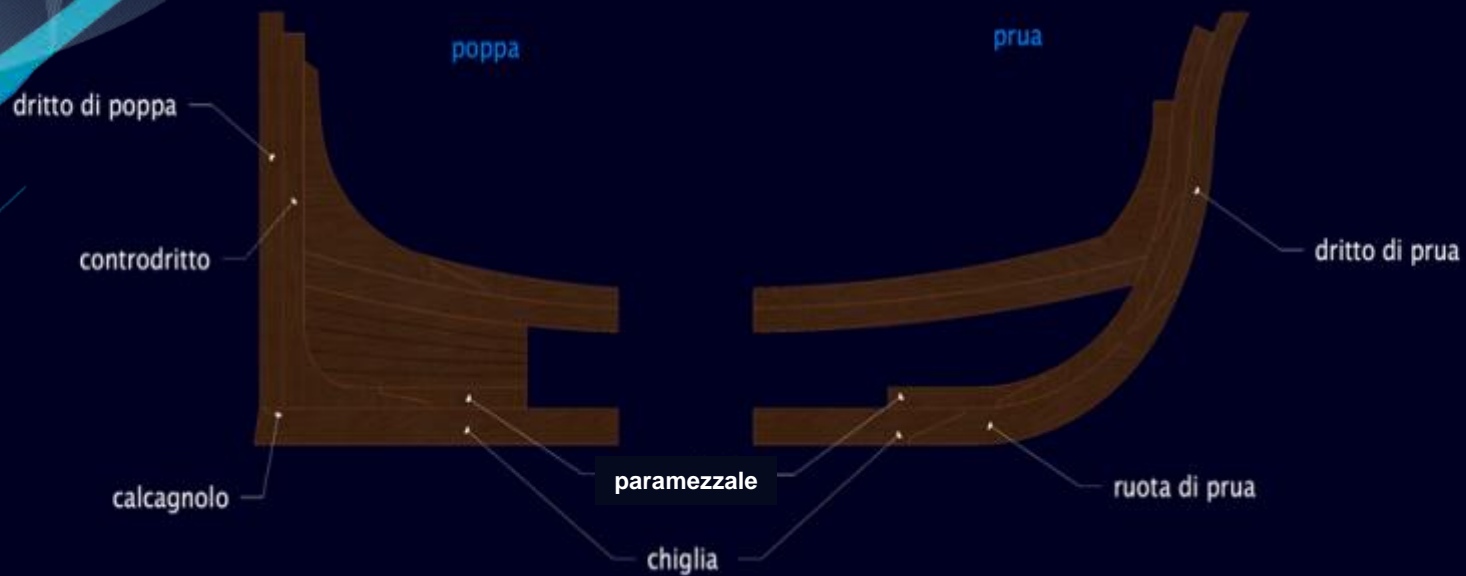

Struttura dello scafo

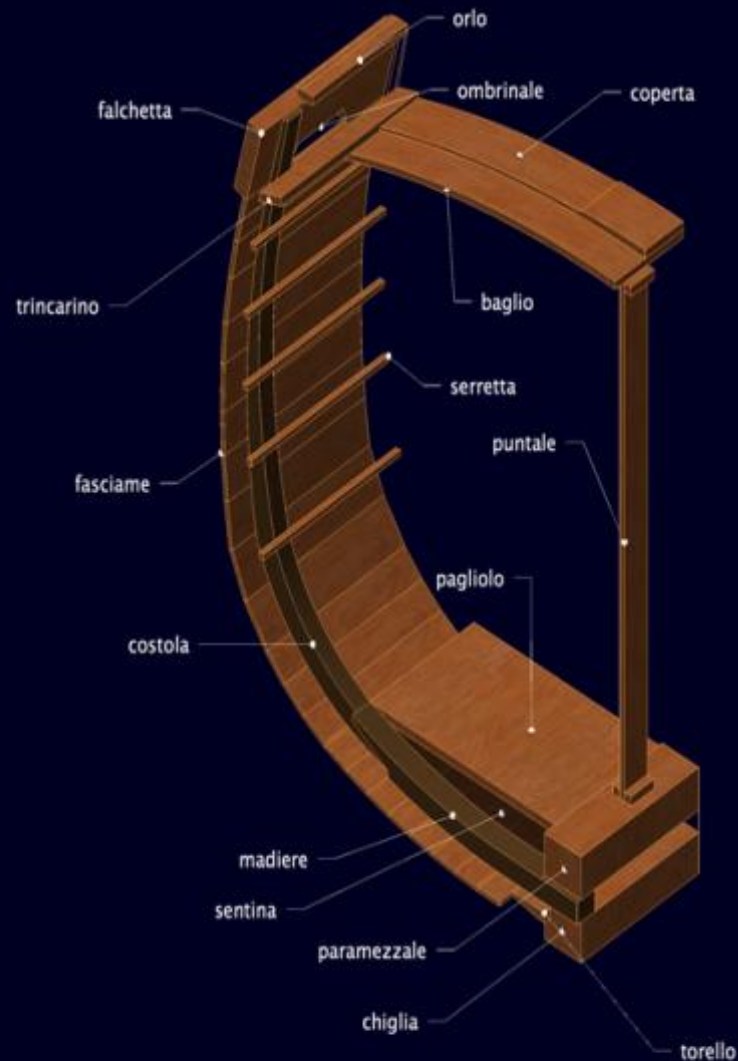

Struttura dello scafo

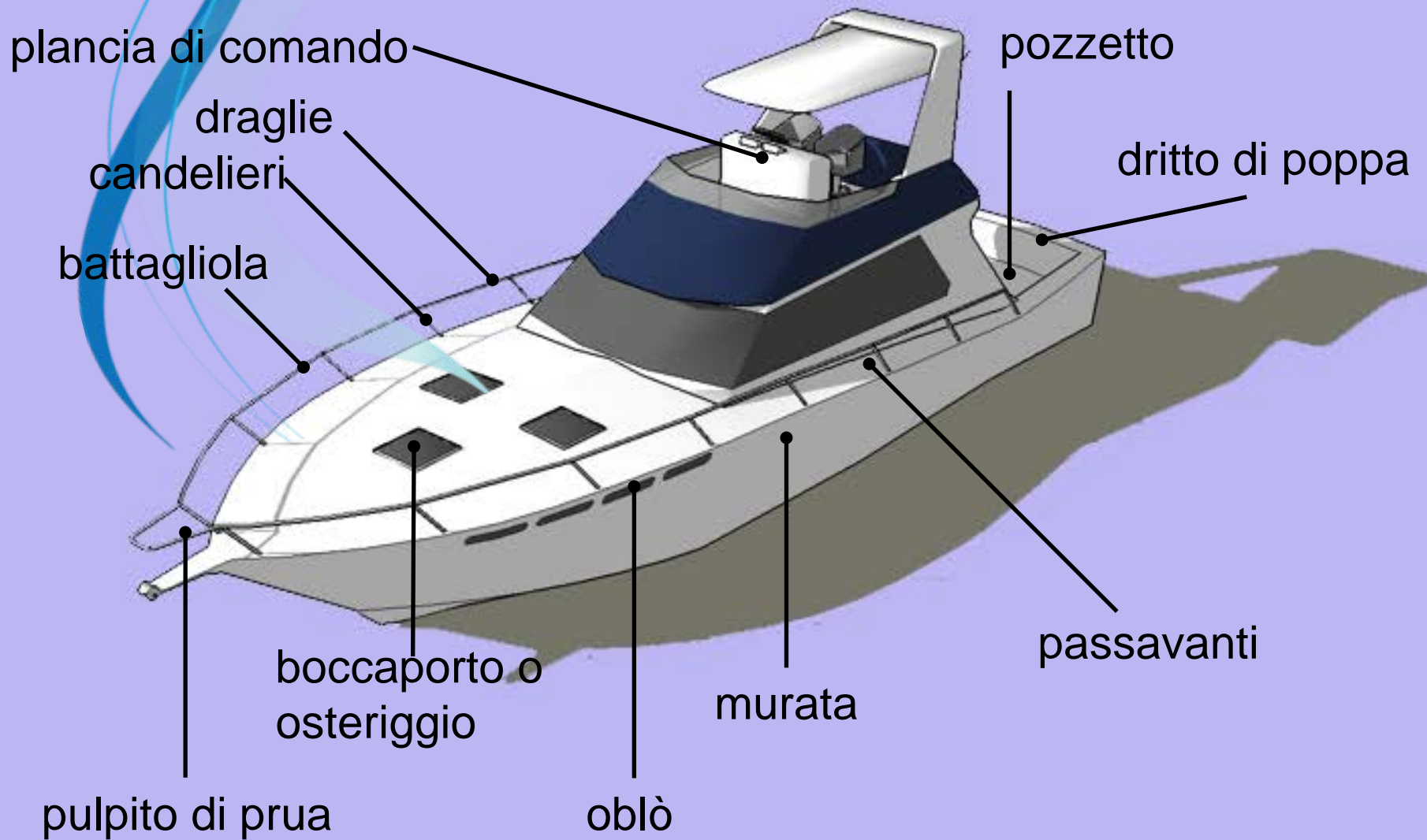



MOTORE

Motore

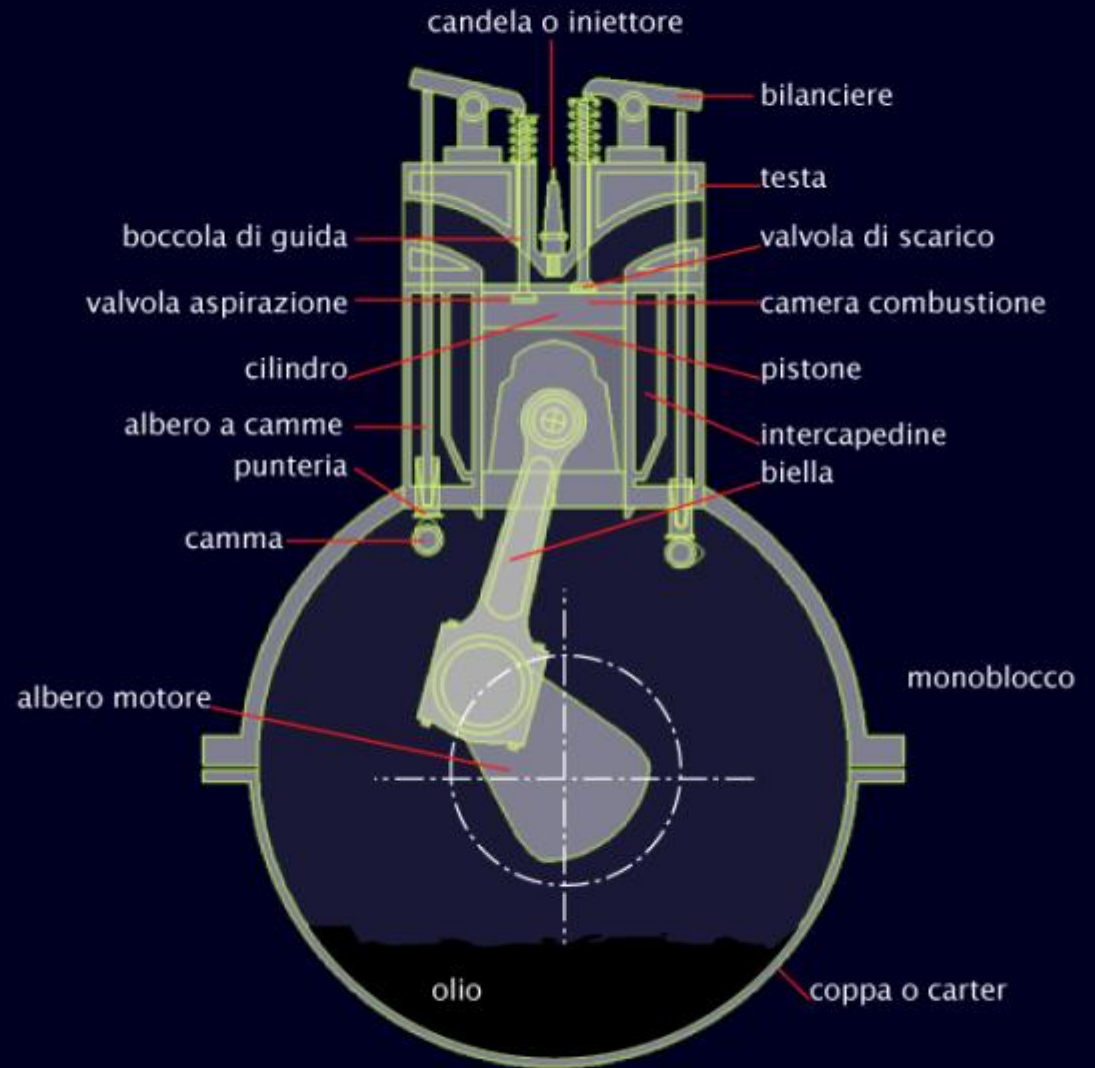

Motore

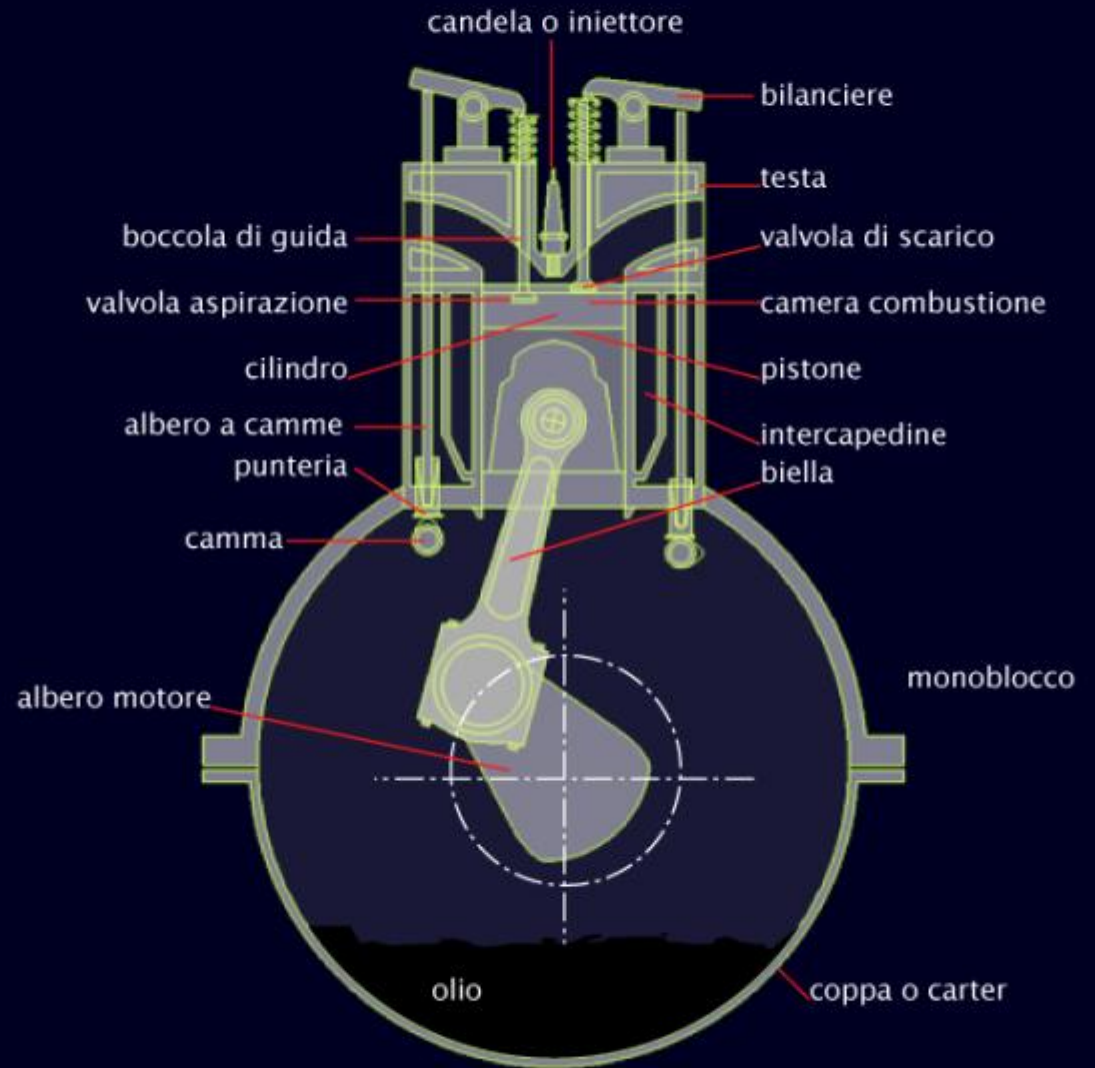

Motore

1^a fase

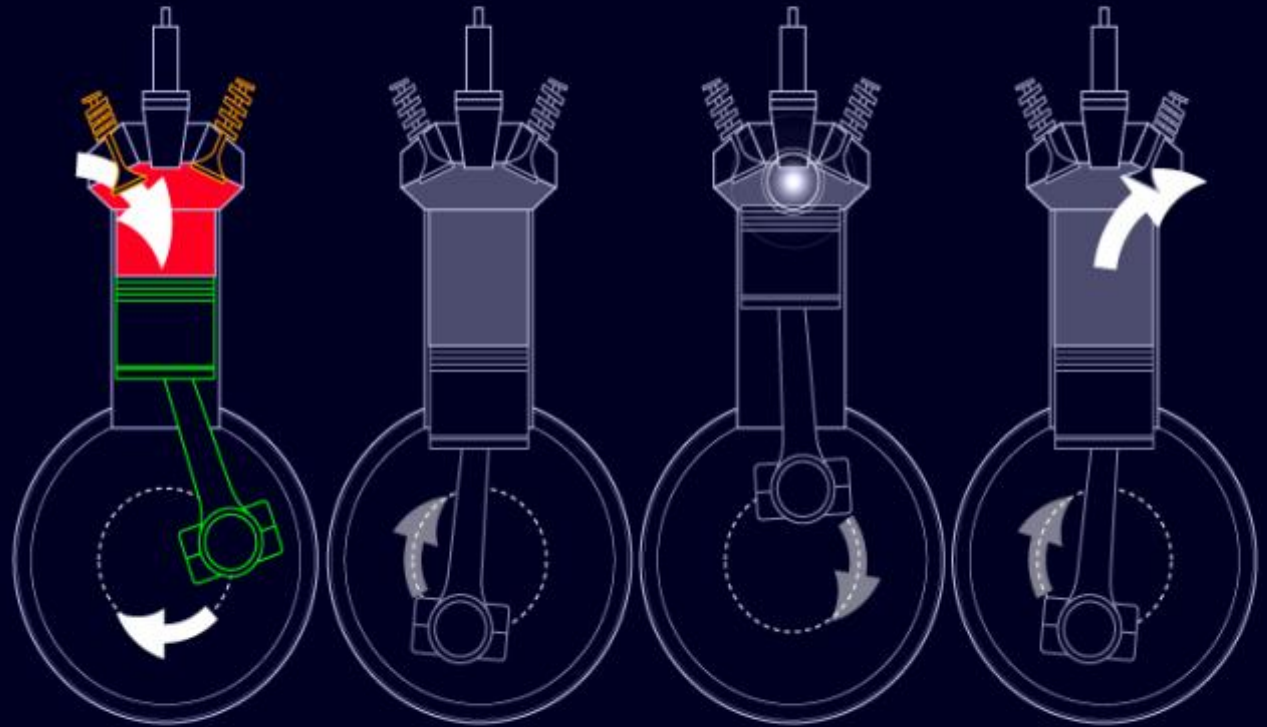

Aspirazione

Motore

2^a fase

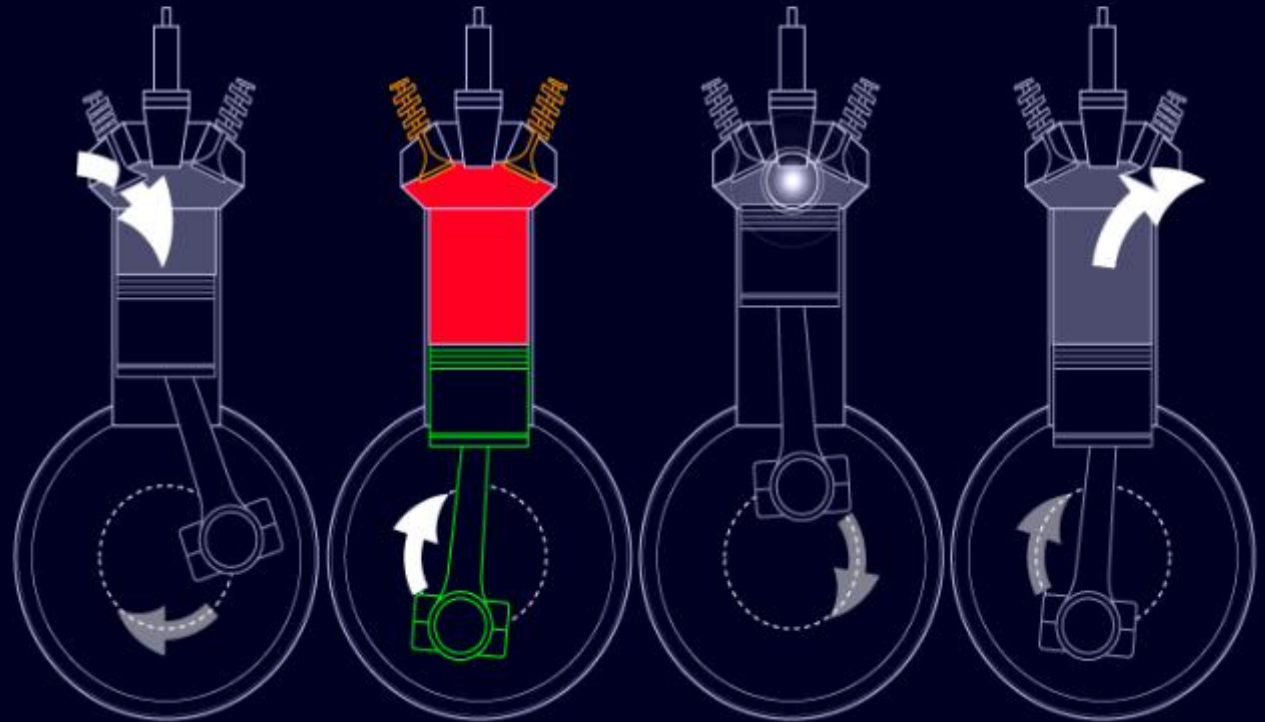

Compressione

Motore

3^a fase

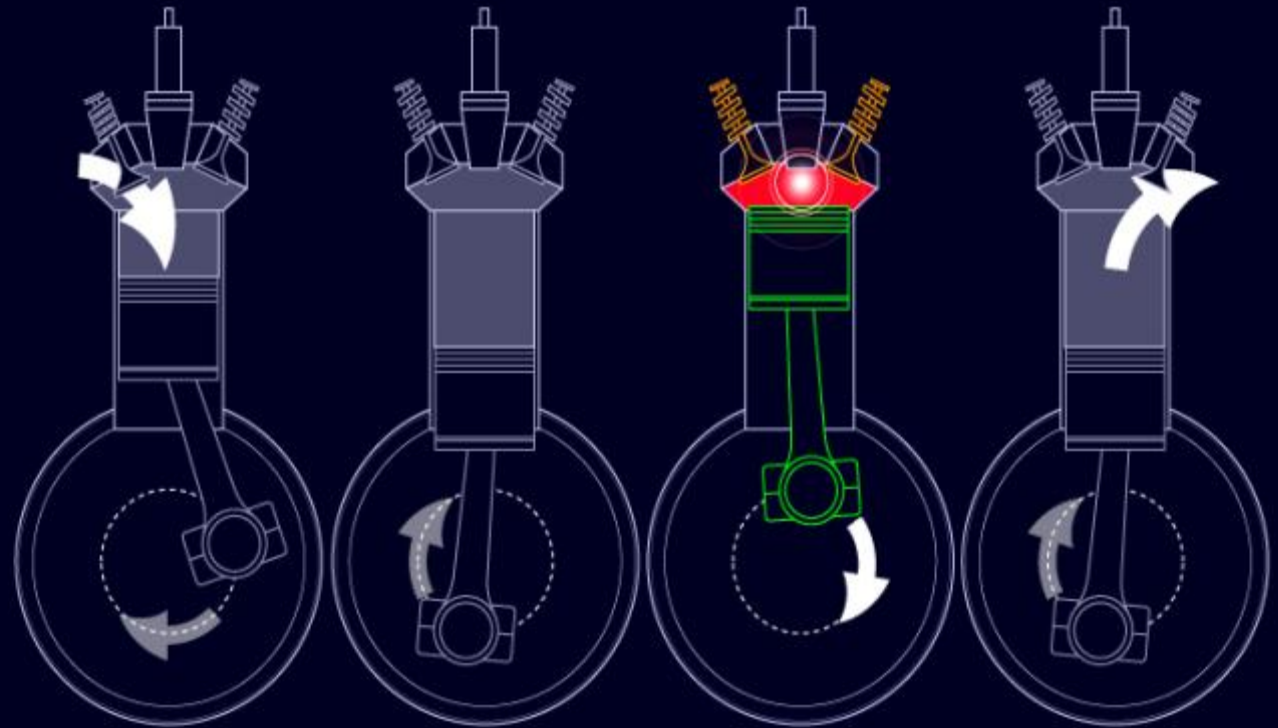

Scoppio

Motore

4^a fase

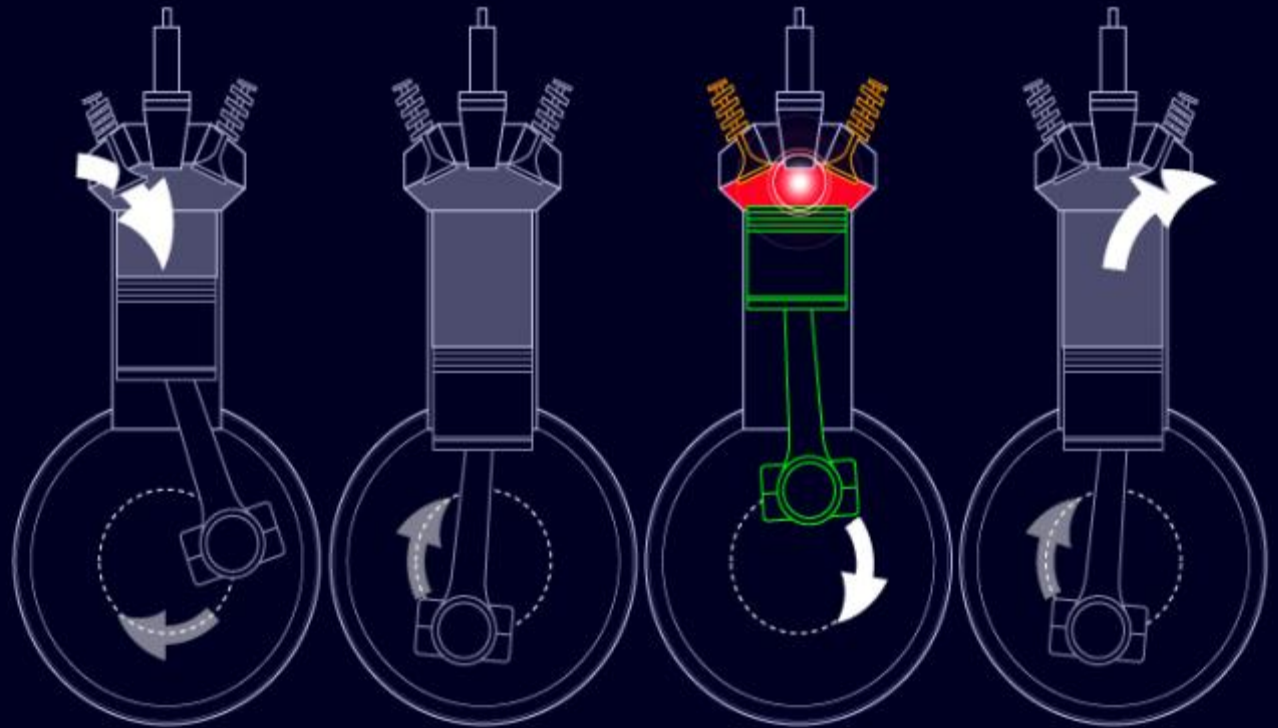

Scarico

Motore Due Tempi

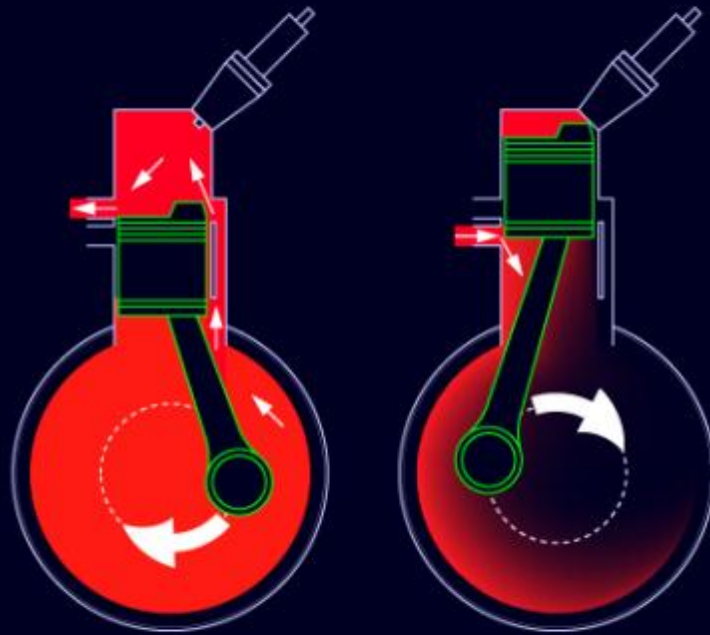

Motore Diesel

1^a fase 2^a fase 3^a fase 4^a fase

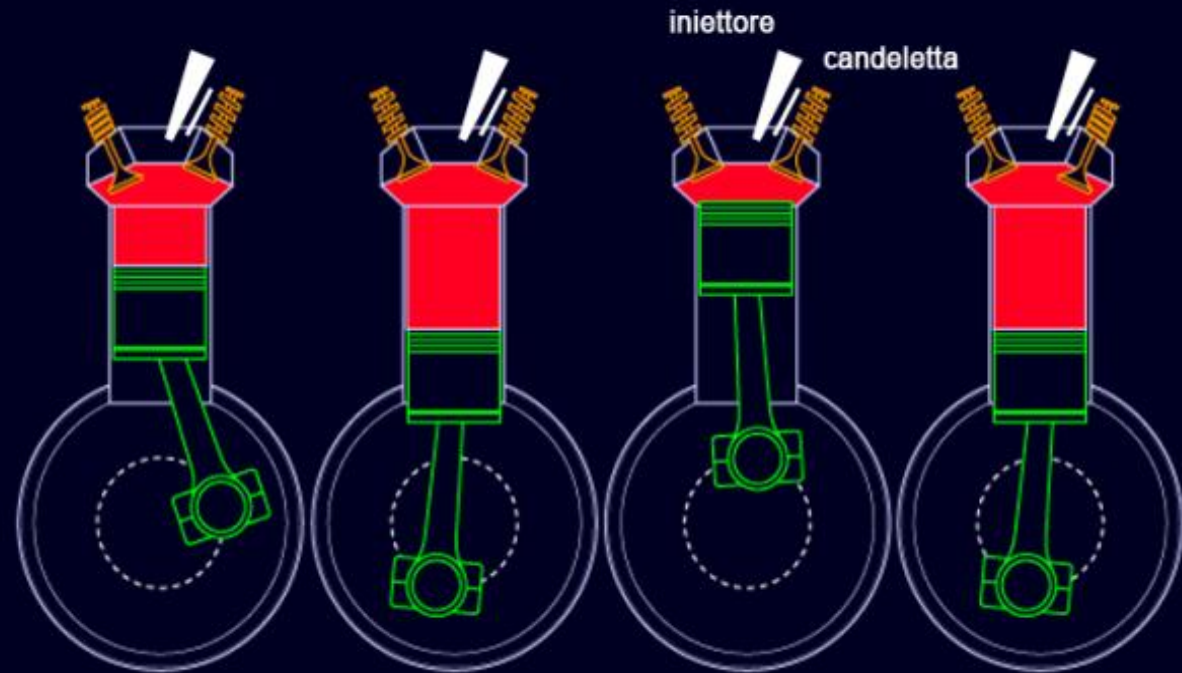

Raffreddamento diretto

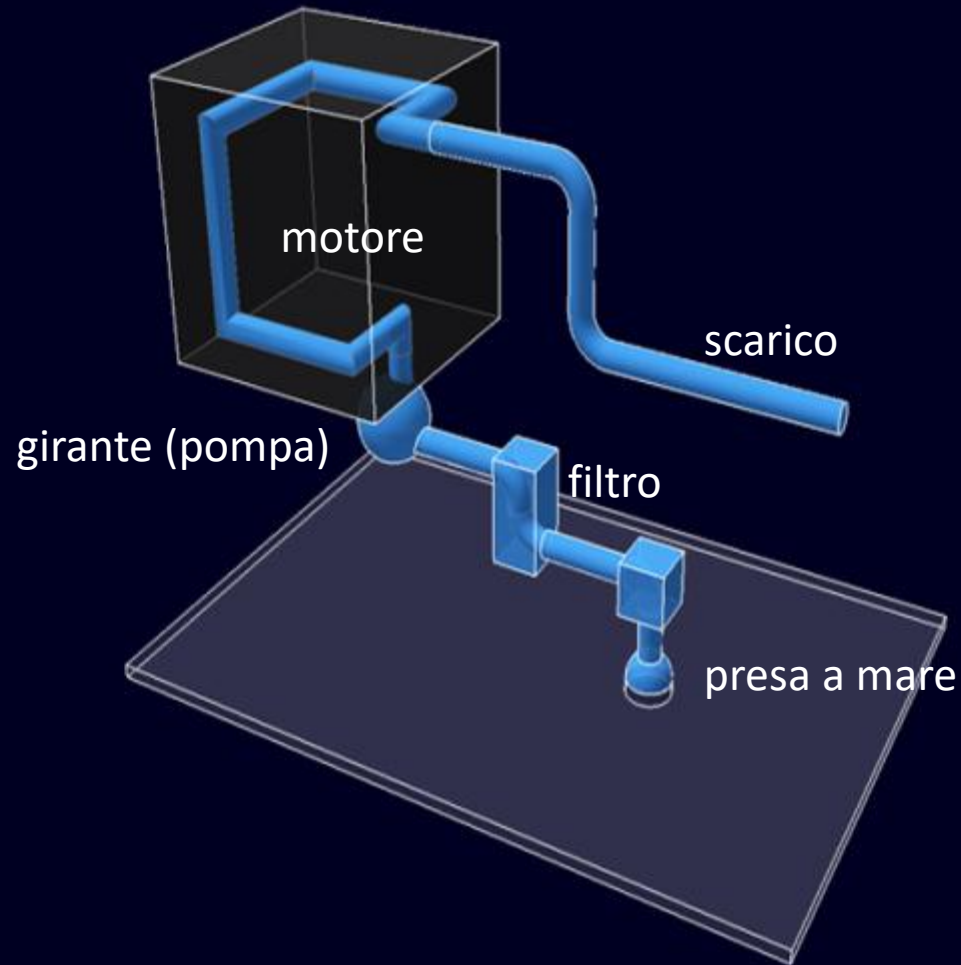

Raffreddamento indiretto

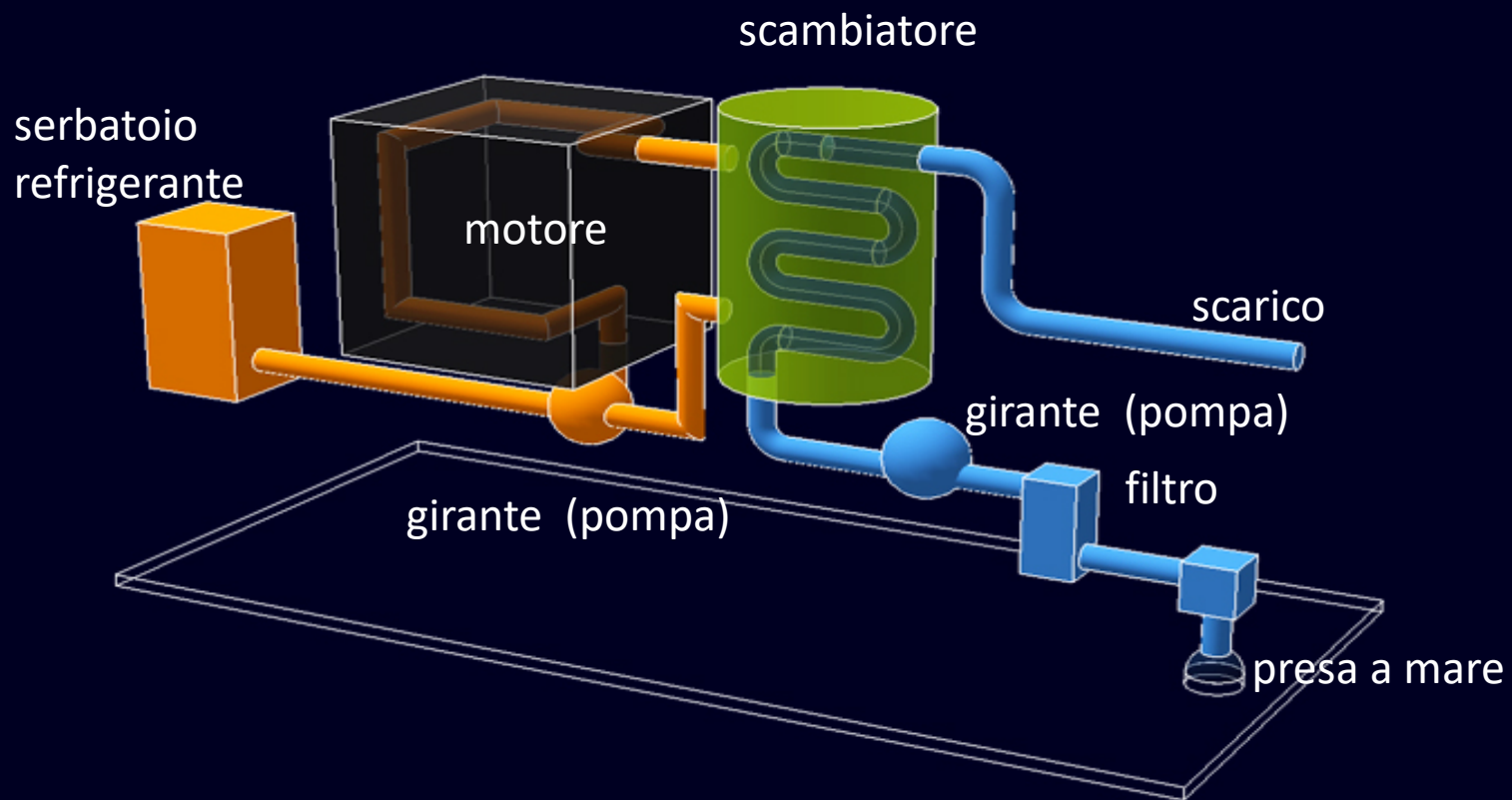

Trasmissione

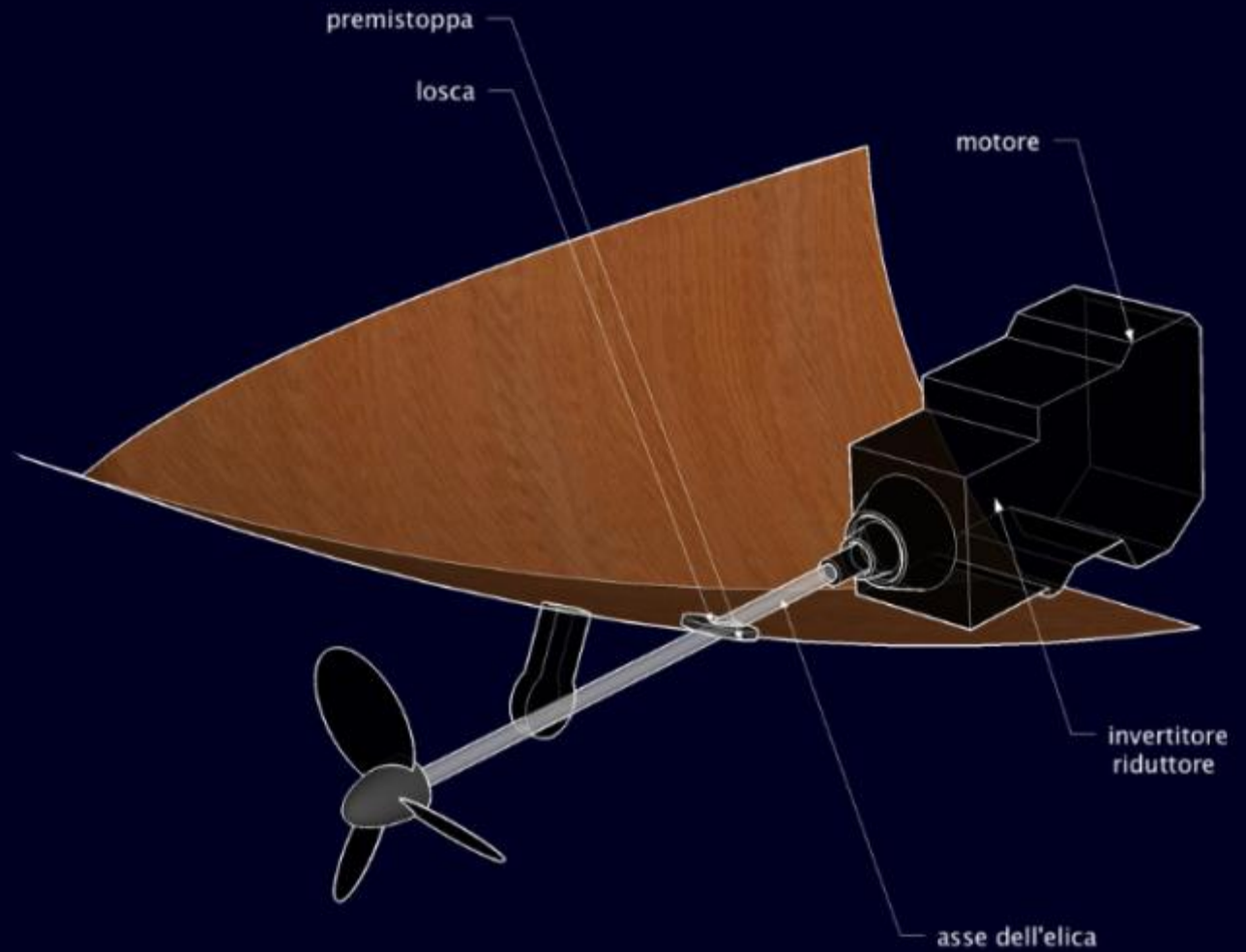

Elica

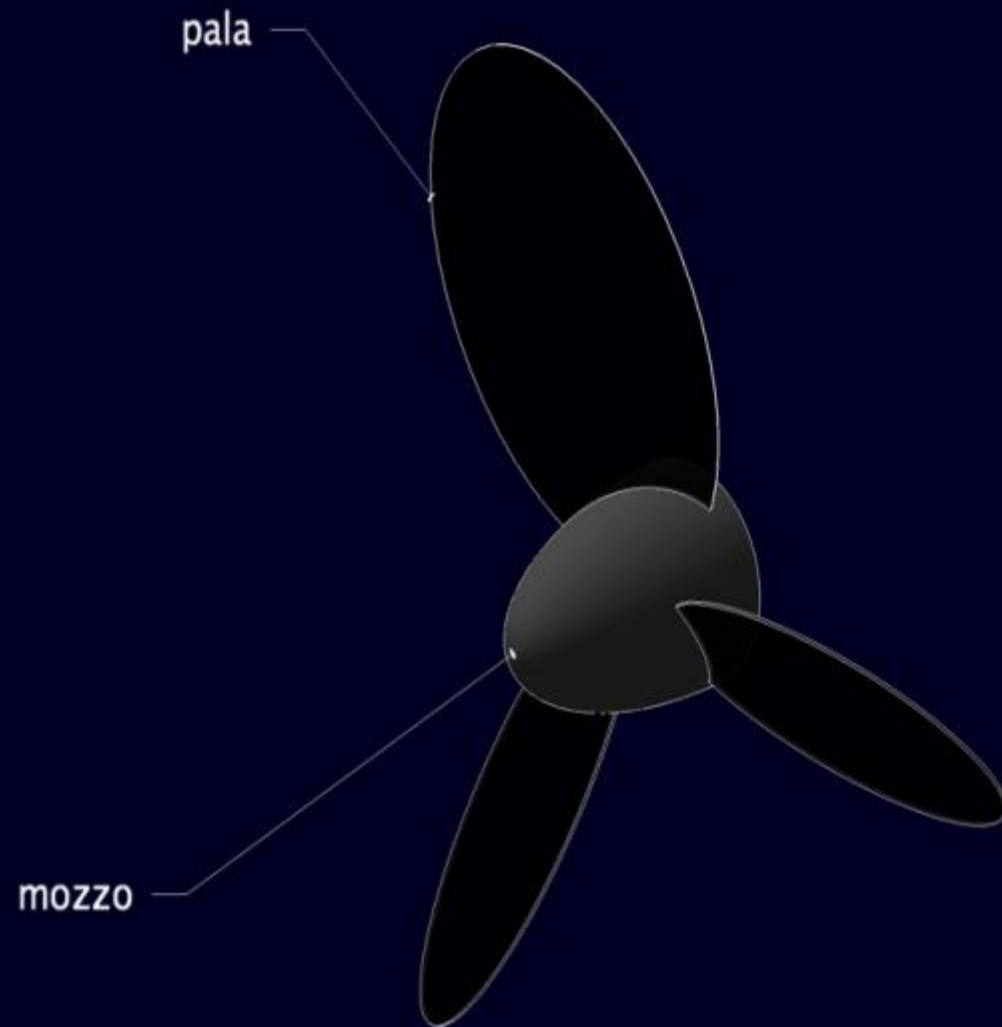

Elica

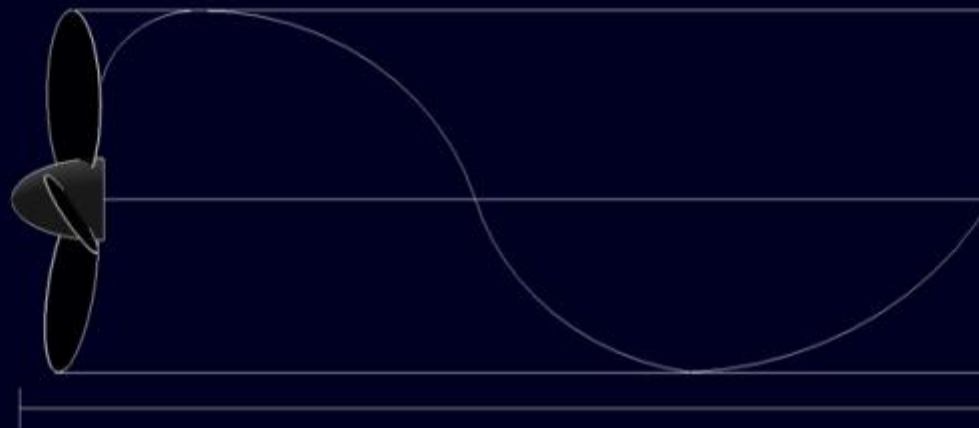

passo teorico

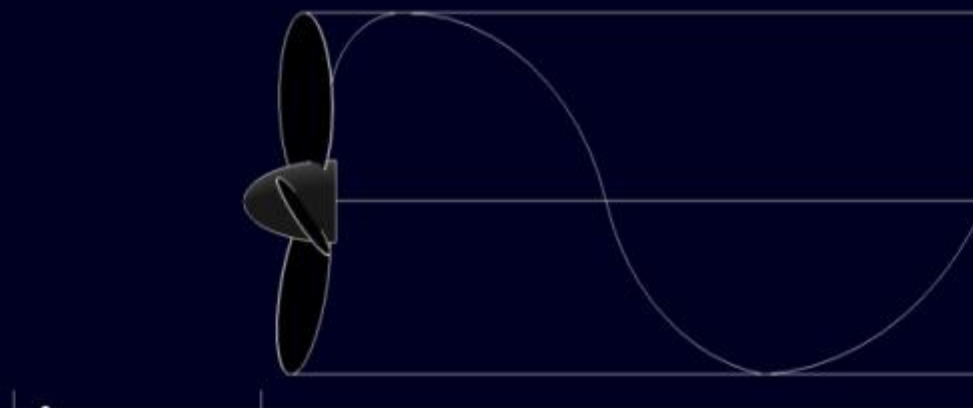

regresso

passo effettivo

Elica

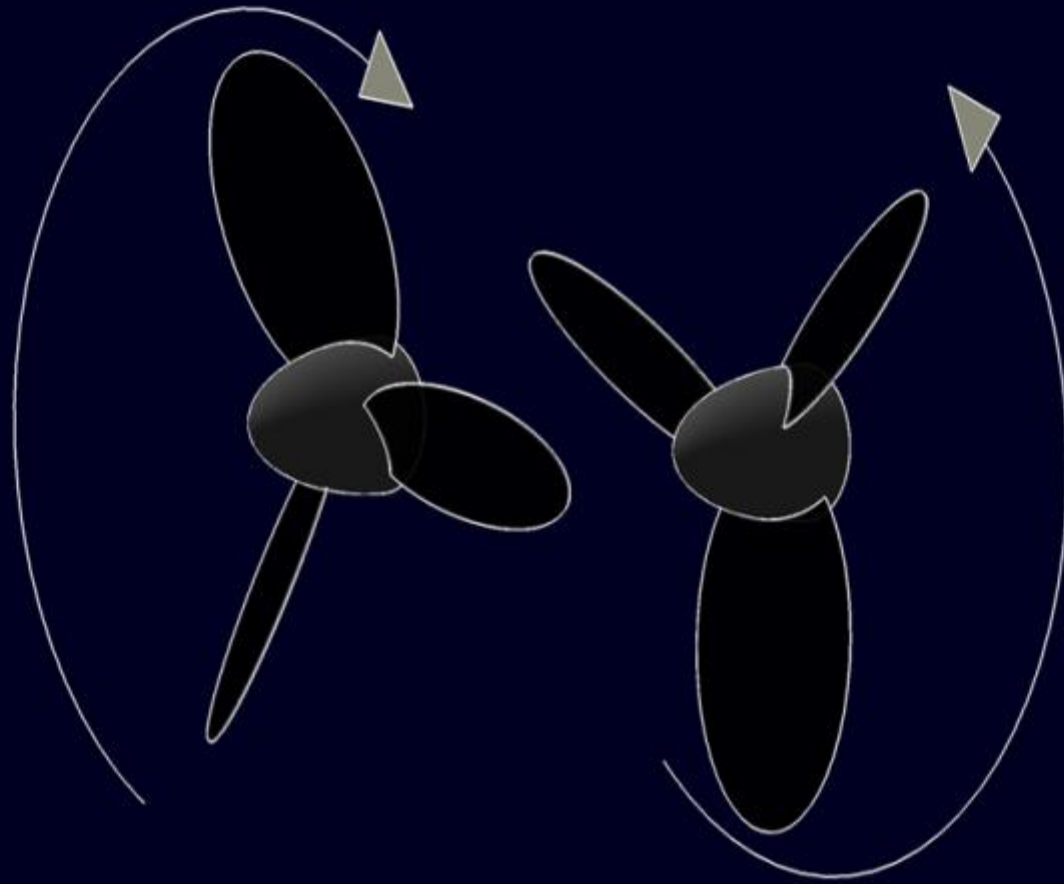

Elica

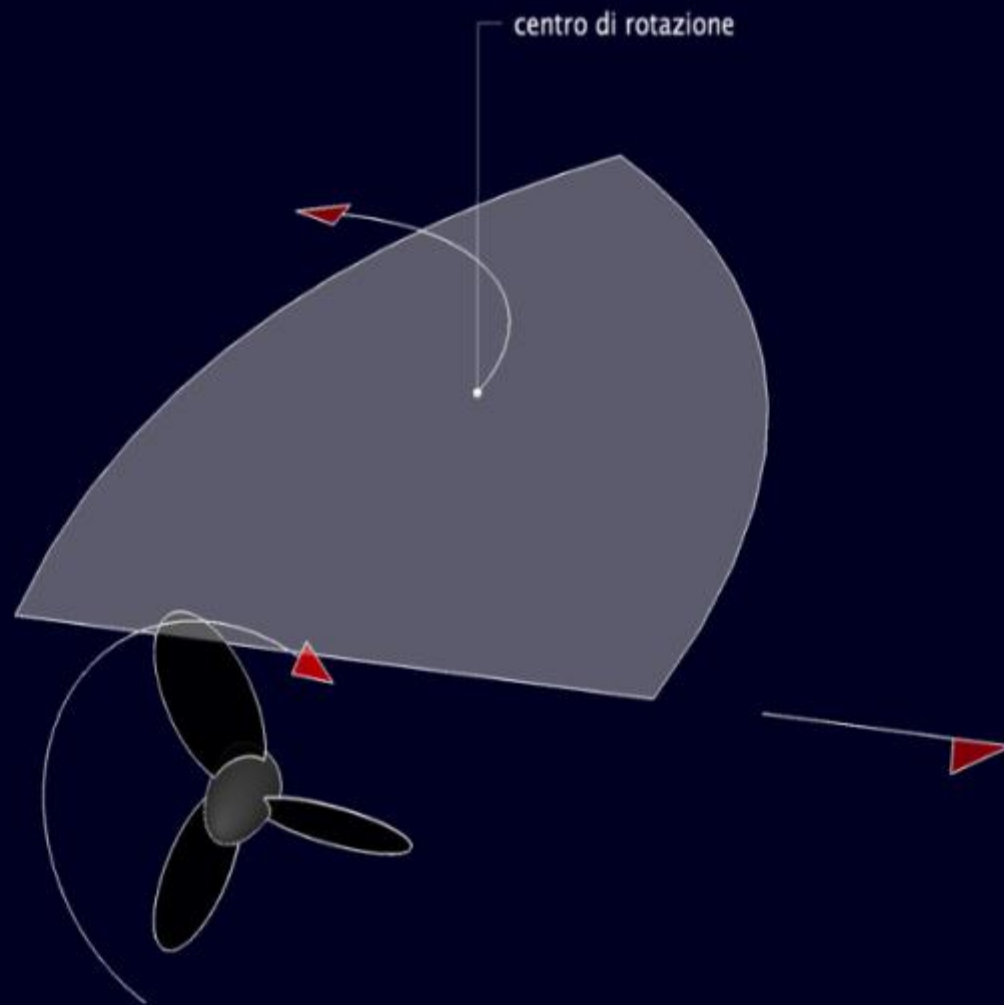

Timone

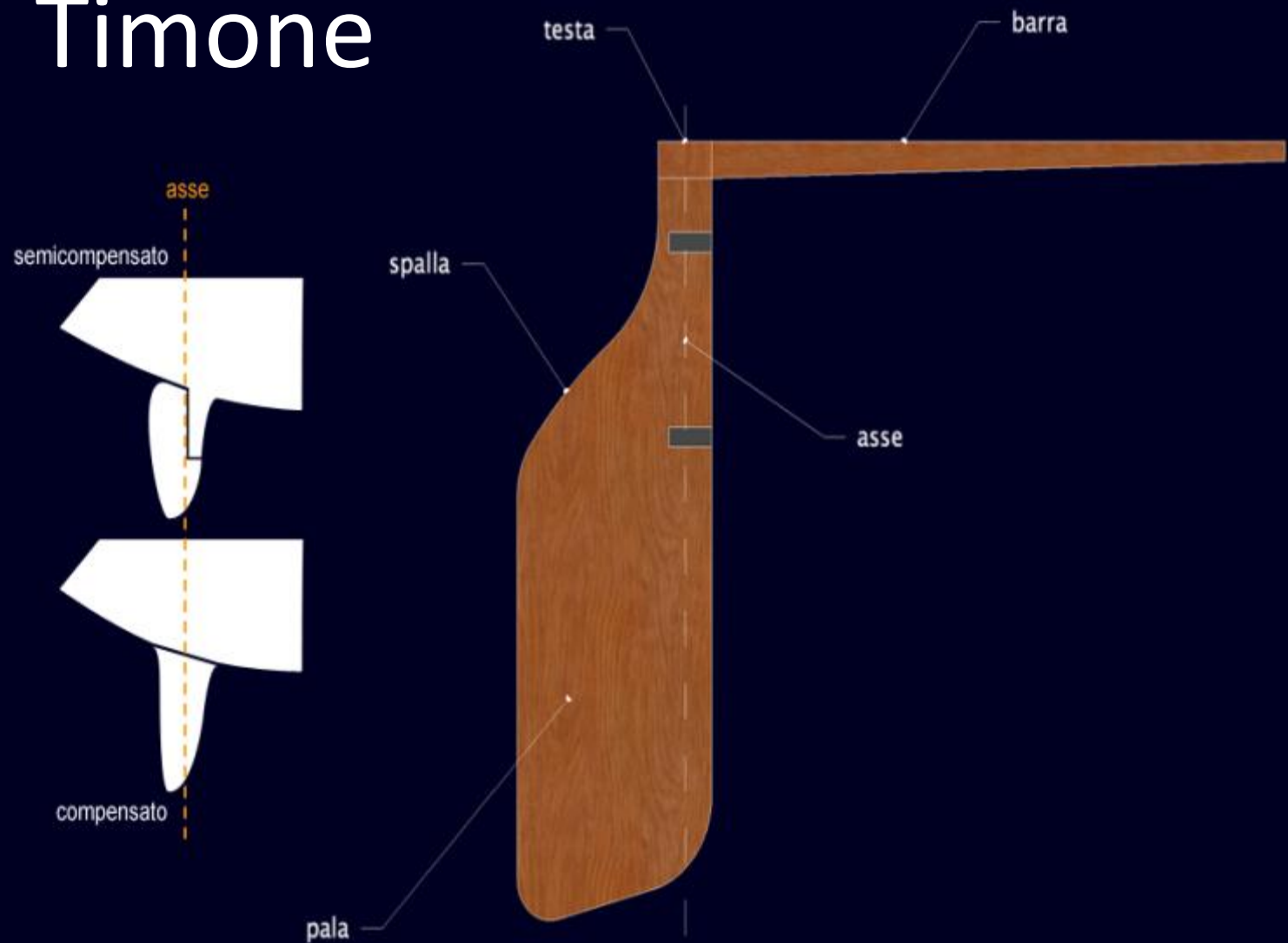

Timone

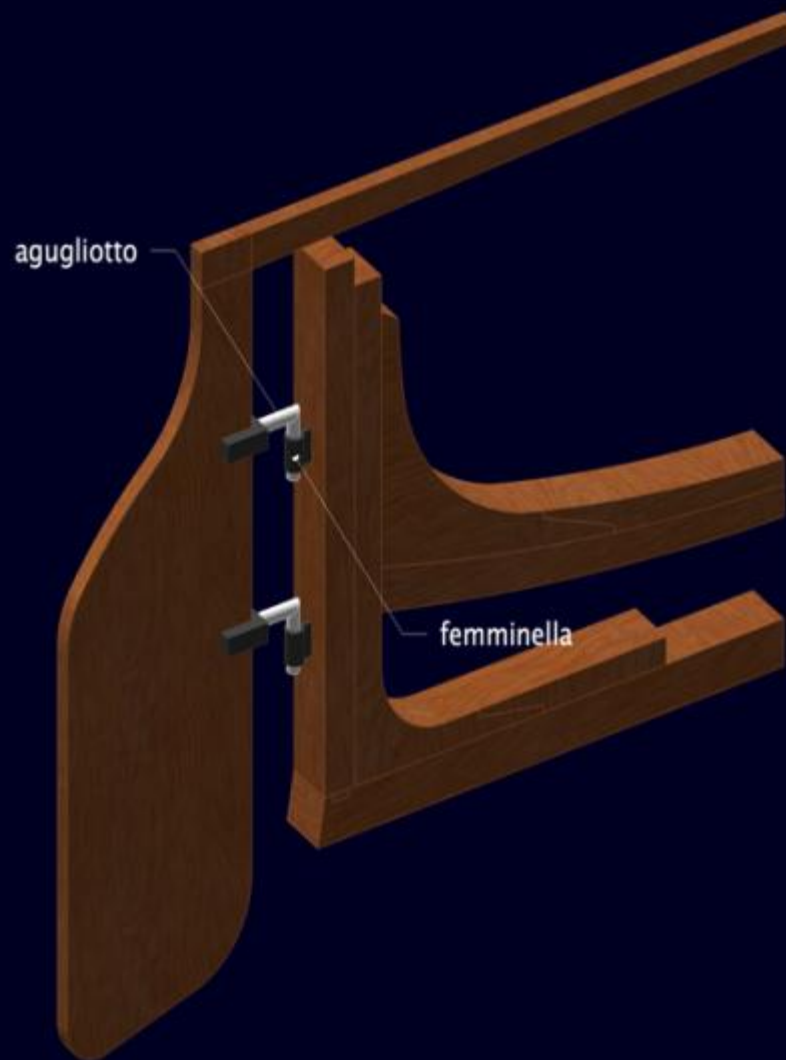

Timone

